

# **MIKE 21 & MIKE 3 FLOW MODEL FM**

**Hydrodynamic Module**

**Short Description**

---



Agern Allé 5            Tel:    +45 4516 9200  
DK-2970 Hørsholm    Support: +45 4516 9333  
Denmark              Fax:    +45 4516 9292

E-mail: [software@dhigroup.com](mailto:software@dhigroup.com)  
Web: [www.dhigroup.com](http://www.dhigroup.com)

**WATER • ENVIRONMENT • HEALTH**

MIKE213\_FM\_Short\_Description\_HD\_.doc/HKH/BHM/AJS/2007Short\_Descriptions.lsm/2007-11-19

## MIKE 21 & MIKE 3 Flow Model FM

The Flow Model FM is a new comprehensive modelling system for two- and three-dimensional water modelling developed by DHI Water & Environment. The new 2D and 3D models carry the same names as the classic DHI model versions MIKE 21 & MIKE 3 with an 'FM' added that refers to the type of model grid - Flexible Mesh.

The modelling system has been developed for complex applications within oceanographic, coastal and estuarine environments. However, being a general modelling system for 2D and 3D free-surface flows it may also be applied for studies of inland surface waters, e.g. overland flooding and lakes or reservoirs.



*MIKE 21 & MIKE 3 Flow Model FM is a new general hydrodynamic flow modelling system based on a finite volume method on an unstructured mesh*

DHI's new Flexible Mesh (FM) series includes the following:

### *Flow Model FM modules:*

- Hydrodynamic Module, HD
- Transport Module, TR
- Ecology and water quality Module, ECO Lab
- Sand Transport Module, ST
- Mud Transport Module, MT

### *Wave module:*

- Spectral Wave Module, SW

The FM Series meets the increasing demand for realistic representations of nature, both with regard to 'look alike' and to its capability to model coupled processes, e.g. coupling between currents,

waves and sediments. Coupling of modules is managed in the Coupled Model FM.

All modules are supported by new advanced user interfaces including efficient and sophisticated tools for mesh generation, data management, 2D/3D visualization, etc. In combination with comprehensive documentation and support, the new FM series forms a unique professional software tool for consultancy services related to design, operation and maintenance tasks within the marine environment.

An unstructured grid provides an optimal degree of flexibility in the representation of complex geometries and enables smooth representations of boundaries. Small elements may be used in areas where more detail is desired, and larger elements used where less detail is needed, optimising information for a given amount of computational time.

The spatial discretisation of the governing equations is performed using a cell-centred finite volume method. In the horizontal plane an unstructured grid is used while a structured mesh is used in the vertical domain (3D).

This document provides a short description of the Hydrodynamic Module included in MIKE 21 & MIKE 3 Flow Model FM.



*Example of computational mesh for Tamar Estuary, UK*

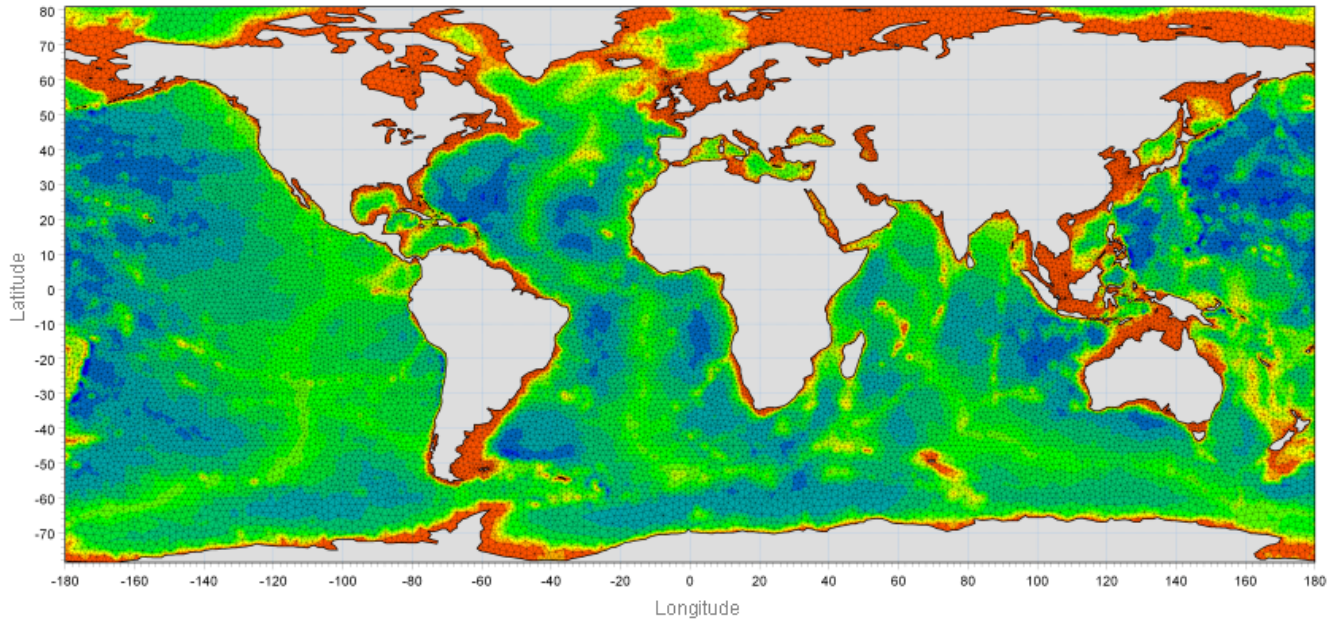

MIKE 21 & MIKE 3 FLOW MODEL FM supports both Cartesian and spherical coordinates. Spherical coordinates are usually applied for regional and global sea circulation applications. The chart shows the computational mesh and bathymetry for the planet Earth generated by the MIKE Zero Mesh Generator

## MIKE 21 & MIKE 3 Flow Model FM - Hydrodynamic Module

The Hydrodynamic Module provides the basis for computations performed in many other modules, but can also be used alone. It simulates the water level variations and flows in response to a variety of forcing functions on flood plains, in lakes, estuaries and coastal areas.

### Application Areas

The Hydrodynamic Module included in MIKE 21 & MIKE 3 Flow Model FM simulates unsteady flow taking into account density variations, bathymetry and external forcings.

The choice between 2D and 3D model depends on a number of factors. For example, in shallow waters, wind and tidal current are often sufficient to keep the water column well-mixed, i.e. homogeneous in salinity and temperature. In such cases a 2D model can be used. In water bodies with stratification, either by density or by species (ecology), a 3D model should be used. This is also the case for enclosed or semi-enclosed waters where wind-driven circulation occurs.

Typical application areas are

- Assessment of hydrographic conditions for design, construction and operation of structures and plants in stratified and non-stratified waters
- Environmental impact assessment studies
- Coastal and oceanographic circulation studies
- Optimization of port and coastal protection infrastructures
- Lake and reservoir hydrodynamics
- Cooling water, recirculation and desalination
- Coastal flooding and storm surge
- Inland flooding and overland flow modelling
- Forecast and warning systems

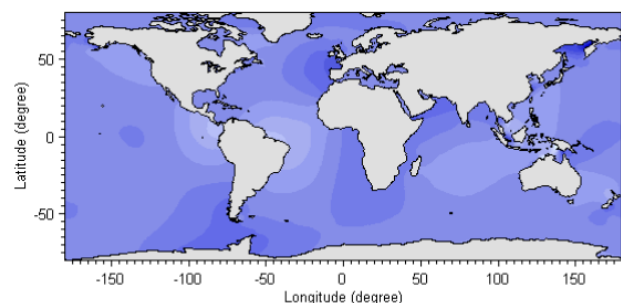

Example of a global tide application of MIKE 21 Flow Model FM. Results from such a model can be used as boundary conditions for regional scale forecast or hindcast models



The MIKE 21 & MIKE 3 Flow Model FM also support spherical coordinates, which makes both models particularly applicable for global and regional sea scale applications.

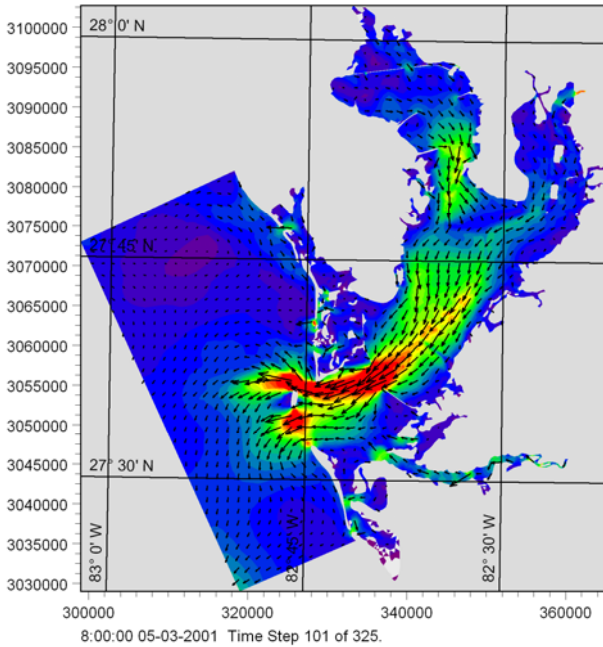

Example of a flow field in Tampa Bay, FL, simulated by MIKE 21 Flow Model FM

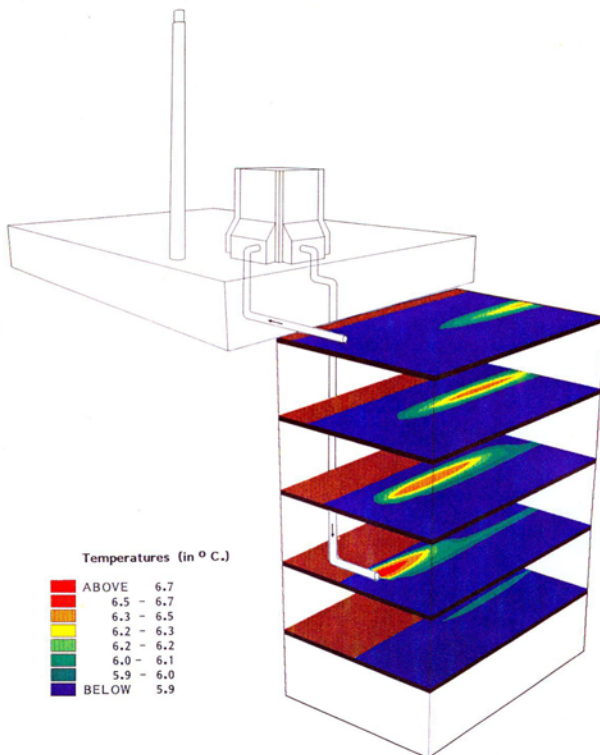

Study of thermal recirculation



Typical applications with the MIKE 21 & MIKE 3 Flow Model FM include cooling water recirculation and ecological impact assessment (eutrophication)

The Hydrodynamic Module is together with the Transport Module (TR) used to simulate the spreading and fate of dissolved and suspended substances. This module combination is applied in tracer simulations, flushing and simple water quality studies.

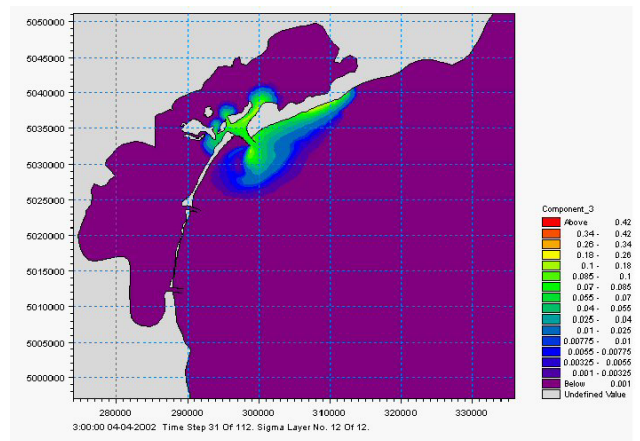

Tracer simulation of single component from outlet in the Adriatic, simulated by MIKE 21 Flow Model FM HD+TR



Prediction of ecosystem behaviour using the MIKE 21 & MIKE 3 Flow Model FM together with ECO Lab

The Hydrodynamic Module can be coupled to the Ecological Module (ECO Lab) to form the basis for environmental water quality studies comprising multiple components.

Furthermore, the Hydrodynamic Module can be coupled to sediment models for the calculation of sediment transport. The Sand Transport Module and Mud Transport Module can be applied to simulate transport of non-cohesive and cohesive sediments, respectively.

In the coastal zone the transport is mainly determined by wave conditions and associated wave-induced currents. The wave-induced currents are generated by the gradients in radiation stresses that occur in the surf zone. The Spectral Wave Module can be used to calculate the wave conditions and associated radiation stresses.

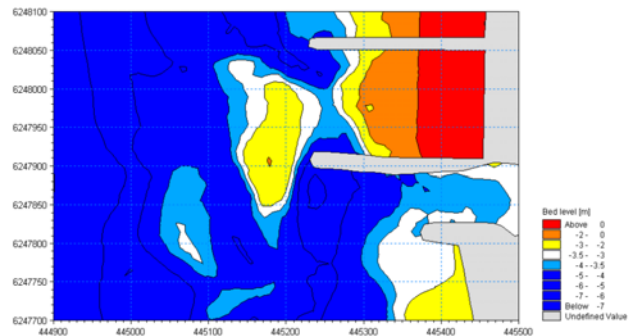

Coastal application (morphology) with coupled MIKE 21 HD, SW and ST, Torsminde harbour Denmark

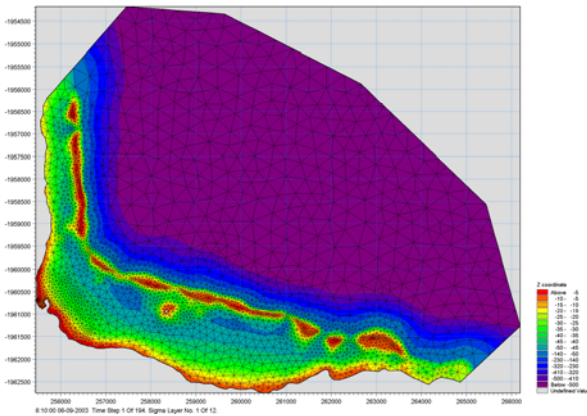



### Computational Features

The main features and effects included in simulations with the MIKE 21 & MIKE 3 Flow Model FM – Hydrodynamic Module are the following:

- Flooding and drying
- Momentum dispersion
- Bottom shear stress
- Coriolis force
- Wind shear stress
- Barometric pressure gradients
- Ice coverage
- Tidal potential
- Precipitation/evaporation
- Wave radiation stresses
- Sources and sinks

### Model Equations

The modelling system is based on the numerical solution of the two/three-dimensional incompressible Reynolds averaged Navier-Stokes equations subject to the the assumptions of Boussinesq and of hydrostatic pressure. Thus, the model consists of continuity, momentum, temperature, salinity and density equations and it is closed by a turbulent closure scheme. The density does not depend on the pressure, but only on the temperature and the salinity.

For the 3D model, the free surface is taken into account using a sigma-coordinate transformation approach.

Below the governing equations are presented using Cartesian coordinates.

The local continuity equation is written as

$$\frac{\partial u}{\partial x} + \frac{\partial v}{\partial y} + \frac{\partial w}{\partial z} = S$$

and the two horizontal momentum equations for the x- and y-component, respectively

$$\frac{\partial u}{\partial t} + \frac{\partial u^2}{\partial x} + \frac{\partial vu}{\partial y} + \frac{\partial wu}{\partial z} = fv - g \frac{\partial \eta}{\partial x} -$$

$$\frac{1}{\rho_0} \frac{\partial p_a}{\partial x} - \frac{g}{\rho_0} \int_z^\eta \frac{\partial \rho}{\partial x} dz + F_u + \frac{\partial}{\partial z} \left( \nu_t \frac{\partial u}{\partial z} \right) + u_s S$$

$$\frac{\partial v}{\partial t} + \frac{\partial v^2}{\partial y} + \frac{\partial uv}{\partial x} + \frac{\partial wv}{\partial z} = -fu - g \frac{\partial \eta}{\partial y} -$$

$$\frac{1}{\rho_0} \frac{\partial p_a}{\partial y} - \frac{g}{\rho_0} \int_z^\eta \frac{\partial \rho}{\partial y} dz + F_v + \frac{\partial}{\partial z} \left( \nu_t \frac{\partial v}{\partial z} \right) + v_s S$$

### Temperature and salinity

In the Hydrodynamic Module, calculations of the transports of temperature,  $T$ , and salinity,  $s$  follow the general transport-diffusion equations as

$$\frac{\partial T}{\partial t} + \frac{\partial uT}{\partial x} + \frac{\partial vT}{\partial y} + \frac{\partial wT}{\partial z} = F_T + \frac{\partial}{\partial z} \left( D_v \frac{\partial T}{\partial z} \right) + \hat{H} + T_s S$$

$$\frac{\partial s}{\partial t} + \frac{\partial us}{\partial x} + \frac{\partial vs}{\partial y} + \frac{\partial ws}{\partial z} = F_s + \frac{\partial}{\partial z} \left( D_v \frac{\partial s}{\partial z} \right) + s_s S$$

*Unstructured mesh technique gives the maximum degree of flexibility, for example: 1) Control of node distribution allows for optimal usage of nodes 2) Adoption of mesh resolution to the relevant physical scales 3) Depth-adaptive and boundary-fitted mesh. Below is shown an example from Ho Bay Denmark with the approach channel to the Port of Esbjerg*

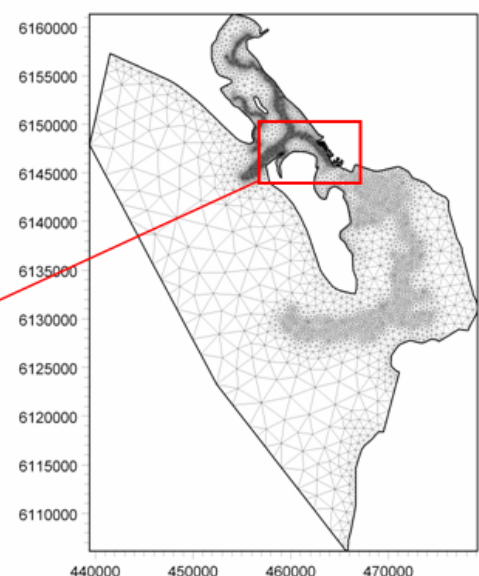
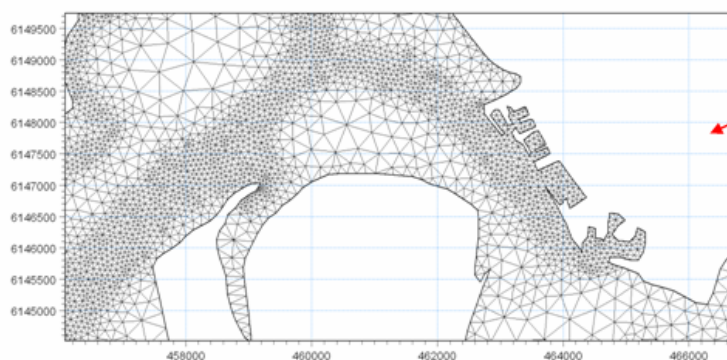

The horizontal diffusion terms are defined by

$$(F_T, F_s) = \left[ \frac{\partial}{\partial x} \left( D_h \frac{\partial}{\partial x} \right) + \frac{\partial}{\partial y} \left( D_h \frac{\partial}{\partial y} \right) \right] (T, s)$$

The equations for two-dimensional flow are obtained by integration of the equations over depth.

Heat exchange with the atmosphere is also included.

### Symbol list

$t$	time
$x, y, z$ :	Cartesian coordinates
$u, v, w$ :	flow velocity components
$T, s$ :	temperature and salinity
$D_v$ :	vertical turbulent (eddy) diffusion coefficient
$\hat{H}$ :	source term due to heat exchange with atmosphere
$S$ :	magnitude of discharge due to point sources
$T_s, S_s$ :	temperature and salinity of source
$F_T, F_s, F_c$ :	horizontal diffusion terms
$D_h$ :	horizontal diffusion coefficient
$h$ :	depth

### Solution Technique

The spatial discretisation of the primitive equations is performed using a cell-centred finite volume method. The spatial domain is discretised by subdivision of the continuum into non-overlapping elements/cells.

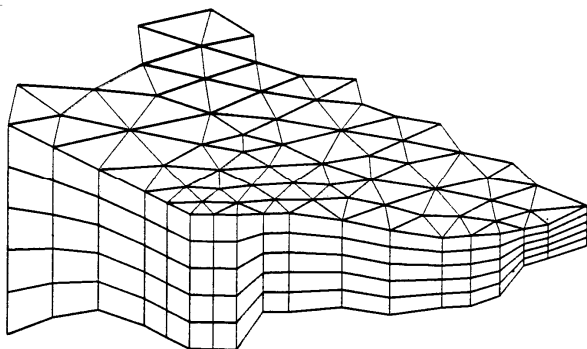

Principle of 3D mesh

In the horizontal plane an unstructured mesh is used while a structured mesh is used in the vertical domain of the 3D model. In the 2D model the elements can be triangles or quadrilateral elements. In the 3D model the elements can be prisms or bricks whose horizontal faces are triangles and quadrilateral elements, respectively.

### Model Input

Input data can be divided into the following groups:

- Domain and time parameters:
  - computational mesh (the coordinate type is defined in the computational mesh file) and bathymetry
  - simulation length and overall time step
- Calibration factors
  - bed resistance
  - momentum dispersion coefficients
  - wind friction factors
- Initial conditions
  - water surface level
  - velocity components
- Boundary conditions
  - closed
  - water level
  - discharge
- Other driving forces
  - wind speed and direction
  - tide
  - source/sink discharge
  - wave radiation stresses

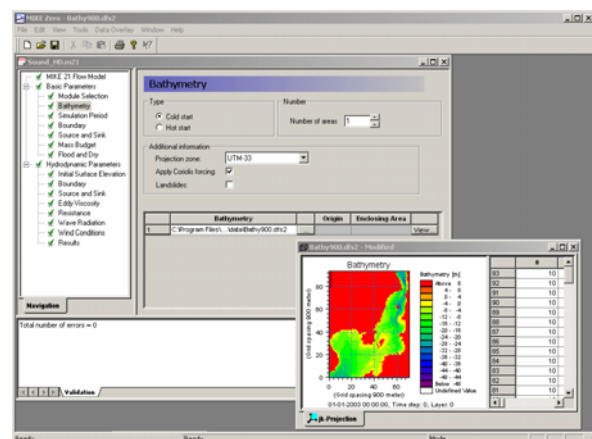

View button on all the GUIs in MIKE 21 & MIKE 3 FM HD for graphical view of input and output files



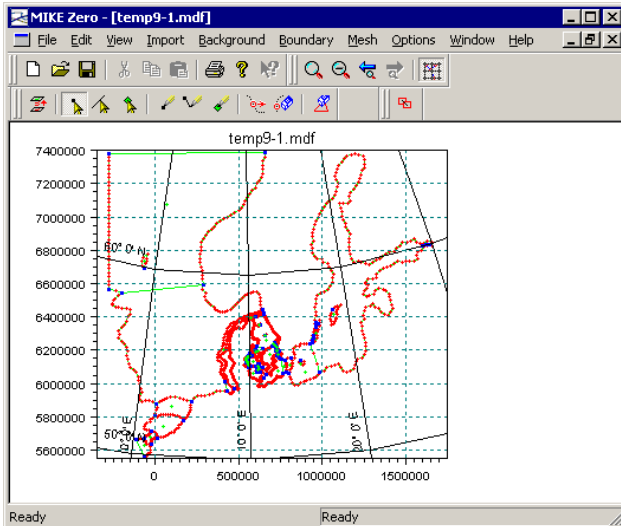

The Mesh Generator is an efficient MIKE Zero tool for the generation and handling of unstructured meshes, including the definition and editing of boundaries

Providing MIKE 21 & MIKE 3 Flow Model FM with a suitable mesh is essential for obtaining reliable results from the models. Setting up the mesh includes the appropriate selection of the area to be modelled, adequate resolution of the bathymetry, flow, wind and wave fields under consideration and definition of codes for defining boundaries.



2D visualization of a computational mesh (Odense Estuary)

Bathymetric values for the mesh generation can e.g. be obtained from the DHI Software product MIKE C-Map. MIKE C-Map is an efficient tool for extracting depth data and predicted tidal elevation from the world-wide Electronic Chart Database CM-93 Edition 3.0 from C-Map Norway.

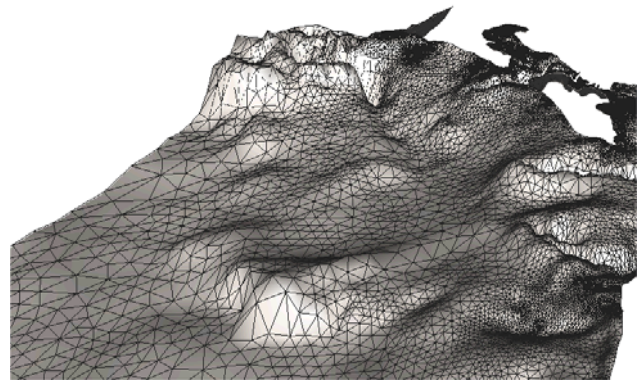

3D visualization of a computational mesh

If wind data is not available from an atmospheric meteorological model, the wind fields (e.g. cyclones) can be determined by using the wind-generating programs available in MIKE 21 Toolbox.

Global winds (pressure & wind data) can be downloaded for immediate use in your simulation. The sources of data are from GFS courtesy of NCEP, NOAA. By specifying the location, orientation and grid dimensions, the data is returned to you in the correct format as a spatial varying grid series or a time series. The link is: [www.dhisoftware.com/mikemarine/online\\_data](http://www.dhisoftware.com/mikemarine/online_data)

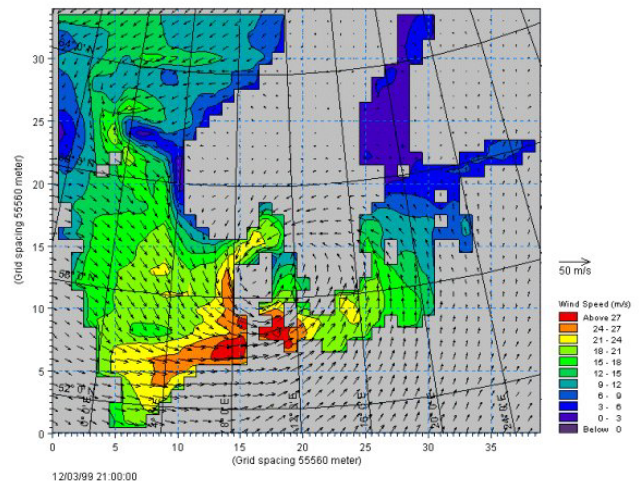

The chart shows a hindcast wind field in the North Sea and Baltic Sea as wind speed and wind direction

## Model Output

Computed output results at each mesh element and for each time step consist of:

- Basic variables
  - water depth and surface elevation
  - flux densities in main directions
  - velocities in main directions
  - densities, temperatures and salinities
- Additional variables
  - Current speed and direction
  - Wind velocities
  - Air pressure
  - Drag coefficient
  - Precipitation/evaporation
  - Courant/CFL number
  - Eddy viscosity

The output results can be saved in defined points, lines and areas. In the case of 3D calculations the results are saved in a selection of layers.

Output from MIKE 21 & MIKE 3 Flow Model FM is typically post-processed using the Data Viewer available in the common MIKE Zero shell. The Data Viewer is a tool for analysis and visualization of unstructured data, e.g. to view meshes, spectra, bathymetries, results files of different format with graphical extraction of time series and line series from plan view and import of graphical overlays.

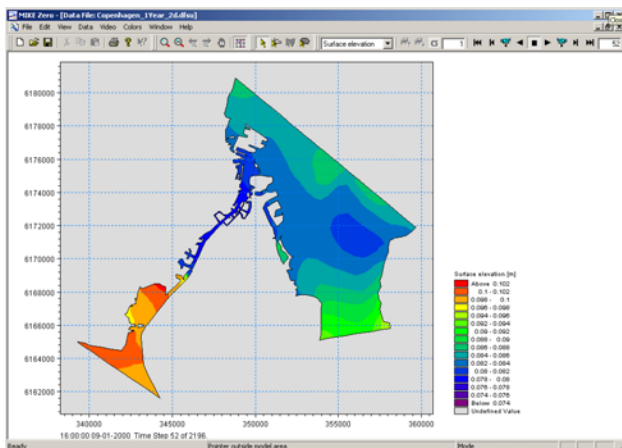

The Data Viewer in MIKE Zero – an efficient tool for analysis and visualization of unstructured data including processing of animations. Above screen dump shows surface elevations from a model setup covering Port of Copenhagen

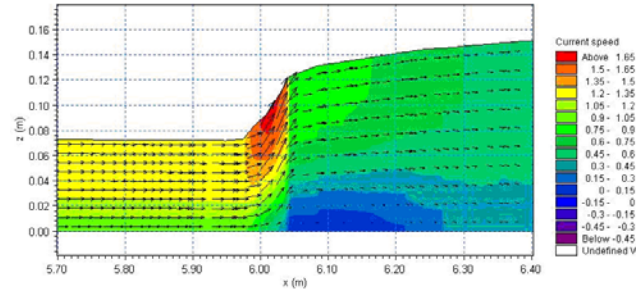

Vector and contour plot of current speed at a vertical profile defined along a line in Data Viewer in MIKE Zero

## Validation

Before the first release of MIKE 21 & MIKE 3 Flow Model FM the model was successfully applied to a number of rather basic idealized situations for which the results can be compared with analytical solutions or information from the literature.

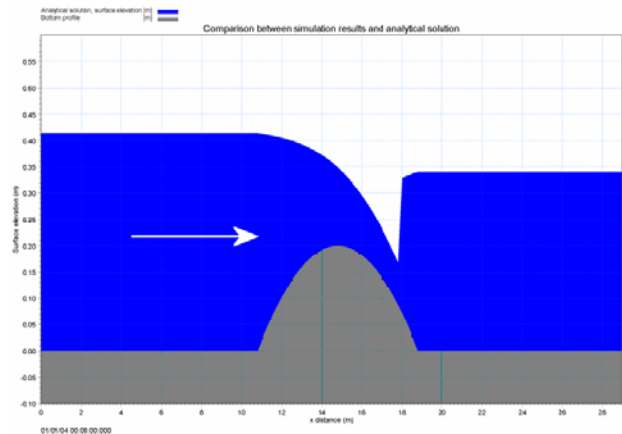

The domain is a channel with a parabola-shaped bump in the middle. The upstream (western) boundary is a constant flux and the downstream (eastern) boundary is a constant elevation. Below: the total depths for the stationary hydraulic jump at convergence. Red line: 2D setup, green line: 3D setup, black line: analytical solution

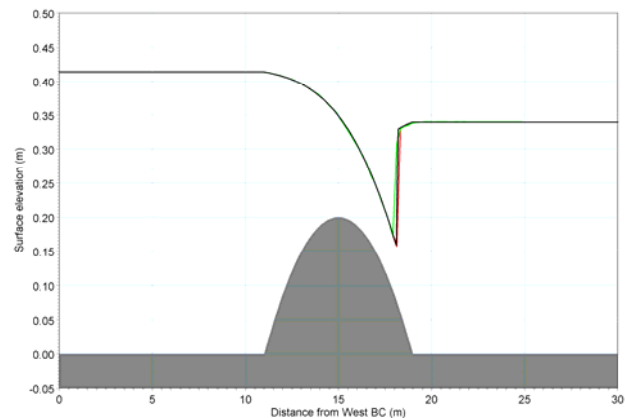



**A dam-break flow in an L-shaped channel (a, b, c):**

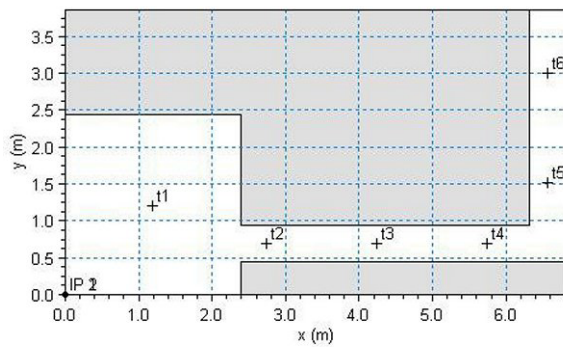

**a) Outline of model setup showing the location of gauging points**

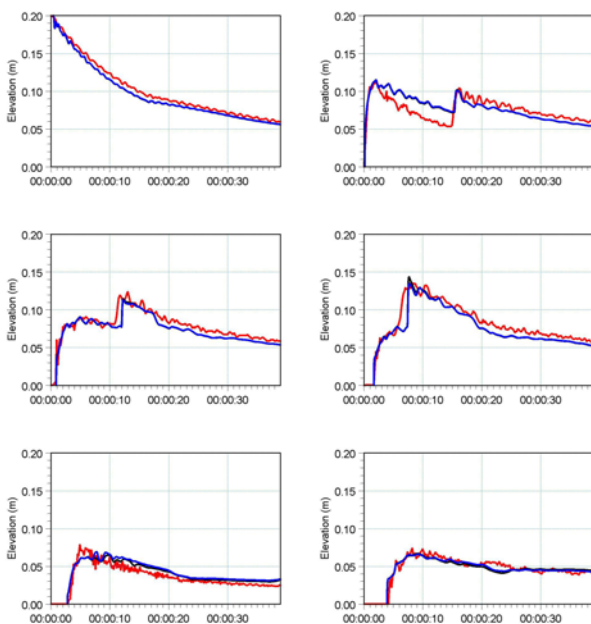

**b) Comparison between simulated and measured water levels at the six gauge locations. (Blue) coarse mesh (black) fine mesh and (red) measurements**

The model has also been applied and tested in more natural geophysical conditions; ocean scale, inner shelves, estuaries, lakes and overland, which are more realistic and complicated than academic and laboratory tests.

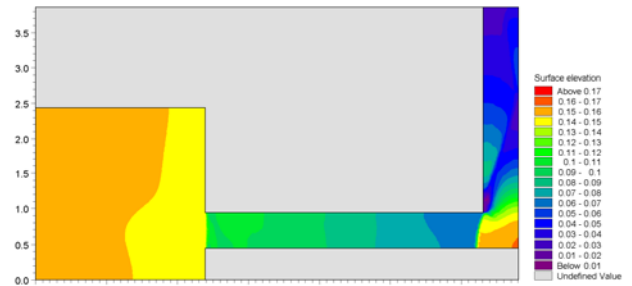
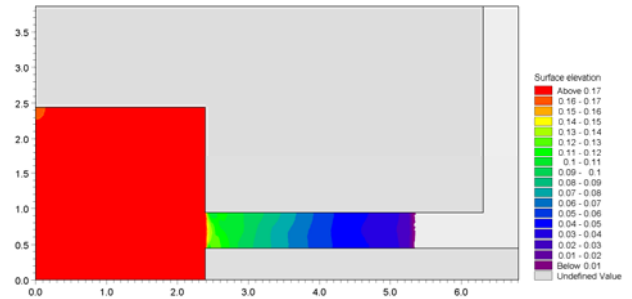

**c) Contour plots of the surface elevation at T = 1.6 s (top) and T = 4.8 s (bottom)**



**Example from Ho Bay, a tidal estuary (barrier island coast) in South-West Denmark with access channel to the Port of Esbjerg. Below: Comparison between measured and simulated water levels**

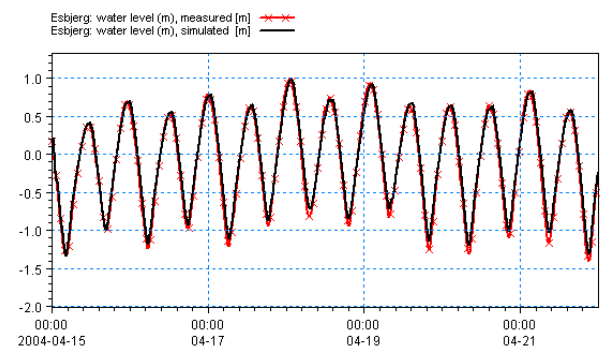

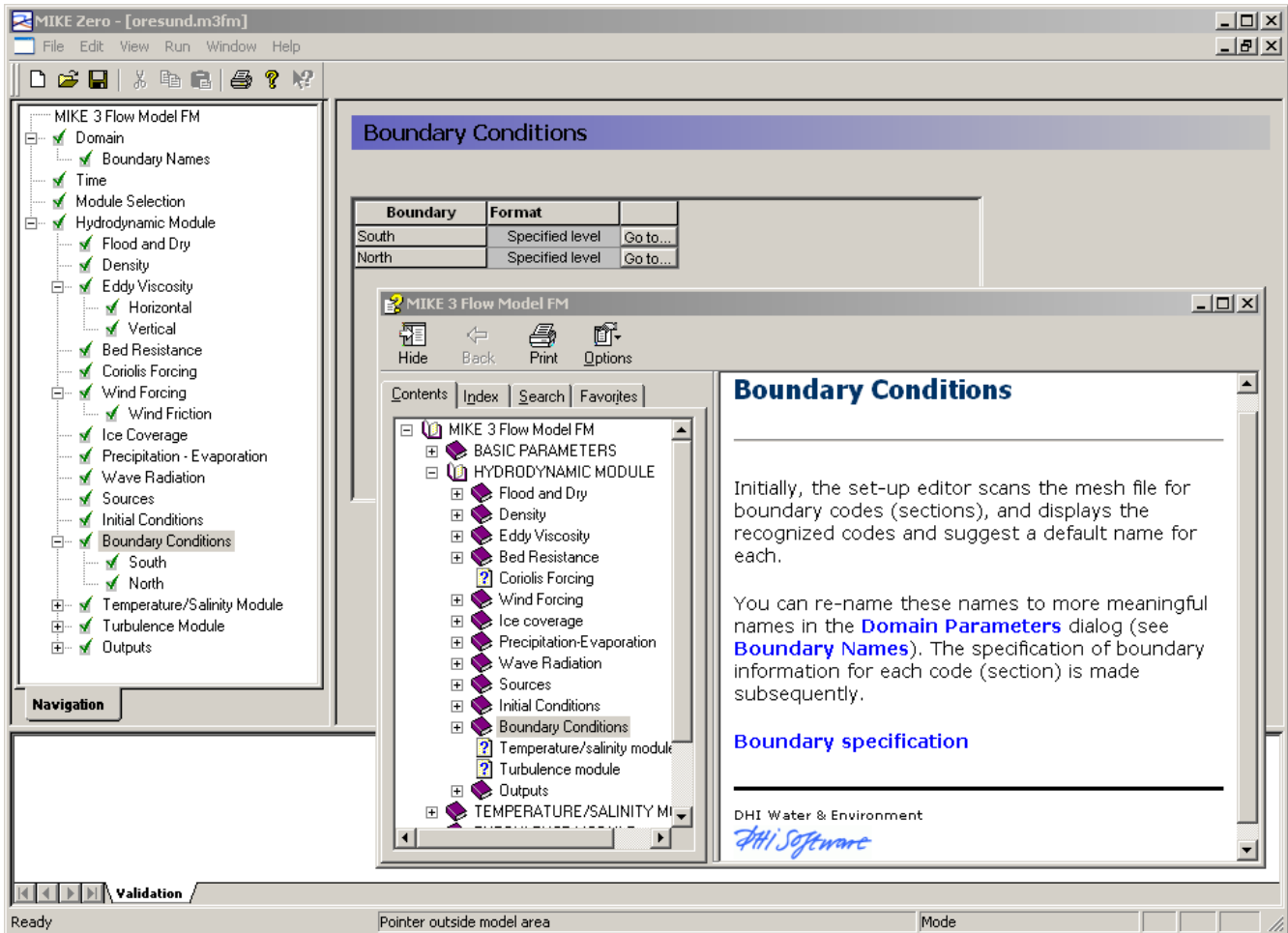

The user interface of the MIKE 21 and MIKE 3 Flow Model FM (Hydrodynamic Module), including an example of the extensive Online Help system

## Graphical User Interface

The MIKE 21 & MIKE 3 Flow Model FM are operated through a fully Windows integrated graphical user interface (GUI). Support is provided at each stage by an Online Help system.

The common MIKE Zero shell provides entries for common data file editors, plotting facilities and a toolbox for/utilities as the Mesh Generator and Data Viewer.

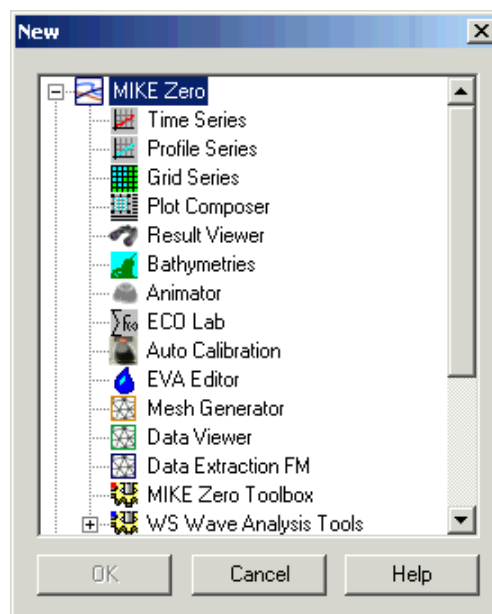

Overview of the common MIKE Zero utilities



## Hardware and Operating System Requirements

The MIKE 21 and MIKE 3 Flow Model FM Hydrodynamic Module supports Microsoft Windows XP and Microsoft Windows Vista. Microsoft Internet Explorer 5.0 (or higher) is required for network license management as well as for accessing the Online Help.

The recommended minimum hardware requirements for executing MIKE 21 & MIKE 3 Flow Model FM are listed below:

Processor:	2 GHz PC (or higher)
Memory (RAM):	1 GB (or higher)
Hard disk:	40 GB (or higher)
Monitor:	SVGA, resolution 1024x768
Graphic card:	32 MB RAM (or higher), 24 bit true colour
Media:	CD-ROM/DVD drive, 20 x speed (or higher)

## Support

News about new features, applications, papers, updates, patches, etc. are available here:

<http://www.dhigroup.com/Software/Download/DocumentsAndTools.aspx>

For further information on MIKE 21 and MIKE 3 Flow Model FM software, please contact your local DHI agent or the Software Support Centre:

Software Support Centre

DHI

Agern Allé 5

DK-2970 Hørsholm

Denmark

Tel: +45 4516 9333

Fax: +45 4516 9292

<http://dhigroup.com/Software.aspx>  
software@dhigroup.com

## References

The MIKE 21 & MIKE 3 Flow Model FM are provided with comprehensive user guides, online help, scientific documentation, application examples and step-by-step training examples.

The MIKE 21 & MIKE 3 Flow Model FM have been, and are, extensively used in DHI consultancy services (some 50 studies in 20 different countries) and in several research projects.



Petersen, N.H., Rasch, P. "Modelling of the Asian Tsunami off the Coast of Northern Sumatra", presented at the 3rd Asia-Pacific DHI Software Conference in Kuala Lumpur, Malaysia, 21-22 February, 2005

French, B. and Kerper, D. Salinity Control as a Mitigation Strategy for Habitat Improvement of Impacted Estuaries. 7<sup>th</sup> Annual EPA Wetlands Workshop, NJ, USA 2004.

DHI Note, "Flood Plain Modelling using unstructured Finite Volume Technique" January 2004 – download from [http://www.dhisoftware.com/mike21/Download/Papers\\_Docs/M21FM\\_Floodplain.pdf](http://www.dhisoftware.com/mike21/Download/Papers_Docs/M21FM_Floodplain.pdf)

